



SAFETY AT THE HIGHEST LEVEL

KeeGuard Premium Operation & Maintenance Manual







KEE SAFETY GUARDRAIL SYSTEMS

Kee Safety's guardrail system KEEGUARD has been designed specifically to provide permanent edge protection for areas where regular access for maintenance and inspection is required.

UNIQUE SYSTEMS

Each system's unique design provides permanent edge protection without the need to mechanically fix the system through the roofing membrane or building's structure. Their simple cantilever principle provides unrivalled strength, stability and safety and overcomes the problems associated with traditional systems such as having to drill and puncture the roof membrane which can lead to potential penetrative water damage and noise disturbance during installation. Similarly, high levels of insulation included within warm deck and inverted flat roof designs often mean it is virtually impossible to fix through, as with traditional systems, without causing cold bridging. This may then cause interstitial condensation to form within the flat roof construction, causing the roof to deteriorate and eventually require replacement. When it is not appropriate to use counter balanced systems, such as modern industrial cladded pitched roofs, KeeGuard Topfix may be an alternative to traditionally fixed systems.



DURABLE SYSTEMS

Kee Safety's guardrail components are supplied with a galvanised finish carried out to BS EN ISO 1461 and ASTM A53: Hot Dip Galvanised Coatings Specification and Testing Methods, giving an average coating of between 65-85 microns. All products are also available in aluminium. All locking screws are stainless steel and are greased before fixing to ensure a maintenance free system.

COMPONENT BASED SYSTEMS

All systems consist of galvanised/aluminium tubing joined together using the KEE KLAMP method of connection. KEEGUARD, raked, radiused and folding systems' base feet connect to the 100% recycled PVC counter weight, giving the system its strength & stability.



VERSATILE SYSTEMS

All systems have been specially designed to fit any shape and size of flat and pitched roofs, even circular designs. The systems can also cope with changes in levels, roof falls and difficult details such as ductwork passing over the roof edge and cable trays/plant mounted at the roof edge. The flexibility of the counter weight & KEE KLAMP design allows the systems to be used on plant congested or complex detailed roofs. The product range has been extended to suit specific requirements and includes the standard design with vertical legs, raked and radiused systems, as well as a folding version for areas where a more discreet form of protection is required. KeeGuard Topfix has also been added to the range to provide collective protection solutions for industrial cladded pitched roofs.



MEMBRANE PROTECTION SYSTEMS

Each system is installed with rubber matting bonded to the underside of metal components which come into contact with the roof membrane. In some cases the counter weight and base foot have sacrificial pads placed between the edge protection components and the roof membrane. This protects the roof membrane from damage via heat transfer or direct contact with components. On warm deck roof construction specifications pedestrian tiles are recommended to be placed where base feet and counter weights are in contact with the roof membrane. Where KeeGuard Topfix is installed a butyl strip is used where the Base Plates are fixed, via rivets, to the roof cladding.

TESTING & CERTIFICATION

Tested in accordance with:-
 EN 13374 Class A.
 EN ISO 14122 Part 3.
 NF E85-003
 EN 1991-1-4
 BS 6399 : Part 2 Code of Practice for Wind Load.

WIND CALCULATED

Wind loading is the most likely regular and demanding force a free standing roof guardrail will encounter during its lifetime. Kee Safety has developed a computerised programme to calculate the design to ensure compliance with the relevant wind loadings relating to the topography, height and location of the project throughout the World.

OFFICIAL DOCUMENTATION

All Systems comply with the following:-
 Work at Height Regulations.
 HSG 33 "Health & Safety in Roof work"
 HSE Construction Sheet No. 21 "Working on flat roofs protection against falls."
 European Union Directives together with requirements of CDM Regulations.

AESTHETICS

The smooth lines of the standard galvanised/aluminium finish can be further enhanced by the application of powder coating to BS 6497 Specification for Powder Organic Coatings, EU Codes with bespoke colour produced to special order. Counter weights are available in black or other colours at an additional cost. Where a more discreet form of protection is required, raked and radiused systems, as well as a folding version are welcomed by Planning Officers due to their improved aesthetics.

SYSTEMS DISTRIBUTORS

All systems are available as a supply and installation service or component supply only. Products are available from Kee Safety directly or one of its licensed distributors.

INDUSTRIAL CLADDED ROOFS

Kee Safety has developed a new collective roof edge protection system, KeeGuard Topfix specifically for metal profile and standing seam roofs up to 45°. Pitched cladded roofs have traditionally been protected using personal fall protection systems which are lower in the hierarchy of controls.

PRODUCT SPECIFICATION

FEATURES :- Free Standing **Non Counter** Weight System.

GENERAL

KeeGuard® Systems do not require physical fixing into the roof's structure/membrane. The complete system's design, manufacture, testing and installation has been externally assessed and tested to EN 13374.

MATERIALS

Steel tubing to BS EN 10255 - 2.9mm
 Steel tubing to EN 10255 – 3.2mm
 All steel components galvanised to BS EN ISO 1461.
 Guardrail top and intermediate rails are produced in steel - 48.3mm external diameter (Wall thickness 2.9mm).
 The vertical support legs are produced in steel - 48.3mm external diameter (Wall thickness 2.9mm).
 All cast clamps used to join the guardrail are galvanised malleable cast iron produced to BS EN 1562 : founding malleable cast iron.
 Bases are manufactured from recycled PVC. They are produced in two halves.
 Where tubing is cut on site zinc rich paint is applied to the cut end of the tube.

LAYOUT

All vertical supports are set at maximum 3m centres depending on the system utilised (See KeeGuard Premium Layout illustration).
 Each vertical leg is inserted into the Recycled PVC Base. The vertical leg is secured in place by tightening the collar inserted within the mould. All stop ends have returns or triple counter weighted, using standard KeeGuard® components or supported by way of a wall/ladder clamp.

TESTING

All systems have been tested to EN 13374: Temporary Edge Protection Systems - Product Specification Test Methods and have been awarded a Class A Pass.

WIND LOADING

All installations are wind speed calculated to BS 6399 : Part 2 : Code of Practice for Wind Loads.



EN 13374

Roof Type	Max Pitch	Tube Size	Tube Thickness	First/End Counter Weight	First/End Bay Length	Subsequent Bay
Mineral Grade Felt						
Restrained	10°	8	2.9mm	CB3	3m	3m
UnRestrained	10°	8	2.9mm	CB3	3m	3m

KEE SAFETY
CANTILEVERED ROOF EDGE PROTECTION
SEPARATING PEOPLE FROM HAZARDS

HEAD OFFICE
 Kee Safety Limited
 Cradley Business Park
 Overwood Road
 Cradley Heath
 West Midlands B64 7DW

(t) +44 (0) 1384 632 188
 (f) +44 (0) 1384 632 192
 (e) info@keesafety.co.uk
 (w) www.keesafety.co.uk

- THIS GUARDRAIL IS TESTED TO EN 13374:EN 14122-3
- DO NOT REMOVE, TAMPER, ADJUST, REMOVE OR ALTER IN ANY WAY THE GUARDRAIL INSTALLATION WITHOUT FIRST CONSULTING KEE SAFETY.
- NO LANYARD LIFE LINE OR FALL ARREST PRODUCTS TO BE ATTACHED TO THE GUARDRAIL AT ANY TIME
- DO NOT ATTACH PLASTIC SHEETING OR ANYTHING THAT WOULD INCREASE THE WIND LOADING ON THE GUARDRAIL.
- IF YOU FIND THE GUARDRAIL HAS BEEN ALTERED OR TAMPERED WITH, CONTACT KEE SAFETY IMMEDIATELY

● RE-TEST ONLY TO BE CARRIED OUT BY AUTHORISED SERVICE AGENT.

SYSTEM PLAQUE - SL 111

Provides details of the system and approvals.
 Material : Plastic.
 Net weight : 0.085kg.

Typical Edge Protection System Layout

FIGURE 1

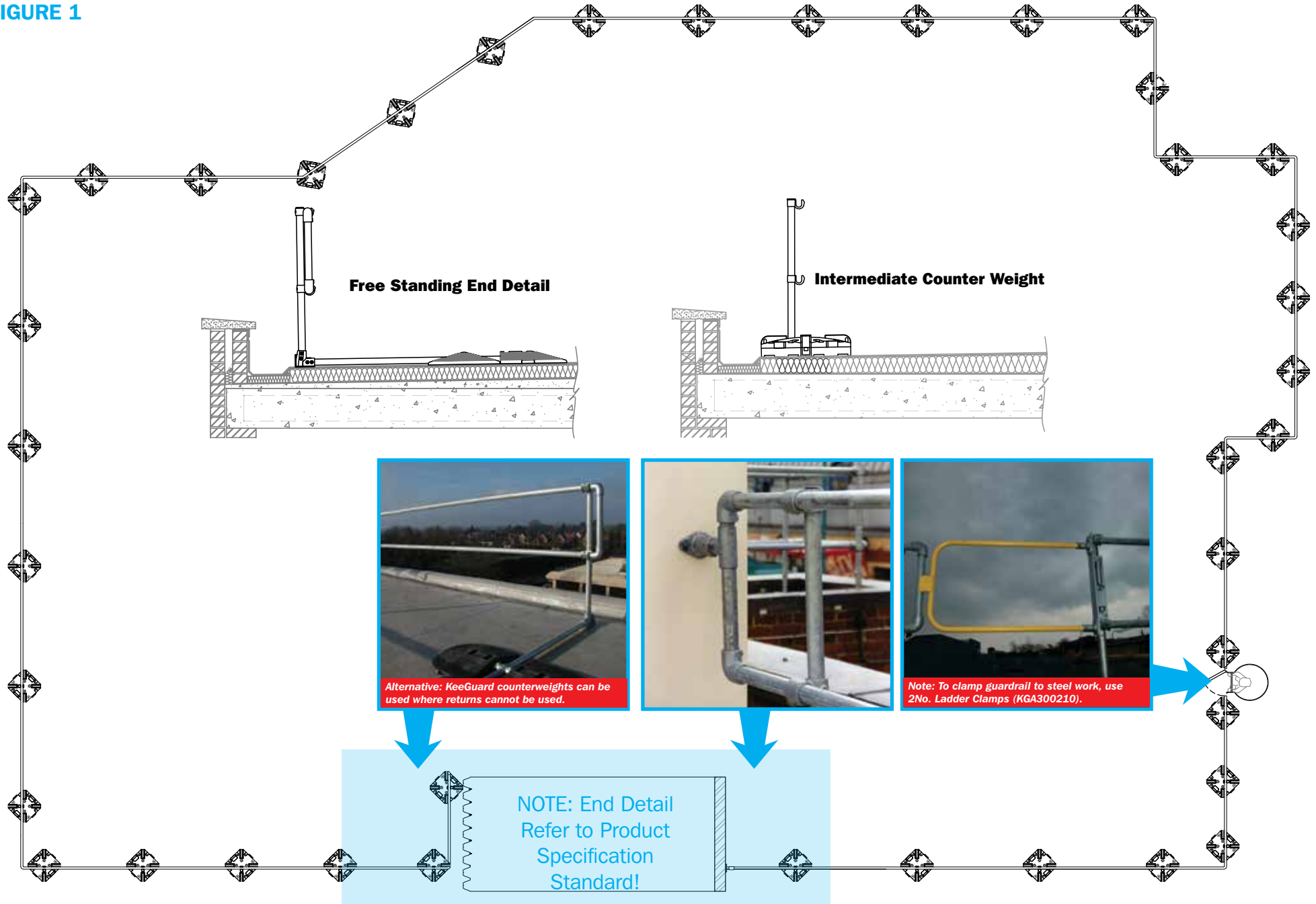

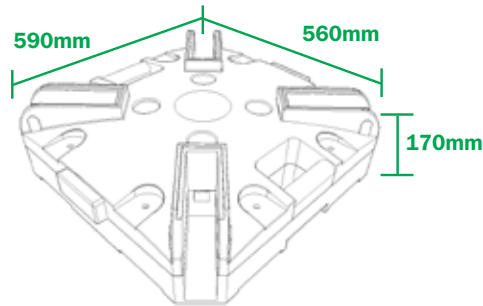

RECYCLED PVC BASE FOOT - 220-8

This unique component provides support to the system and allows the system to be set at 90°. Vertical Support Legs are inserted into the Base Foot and secured by tightening the collar. This component is easily split into two parts for manual handling compliance.
Material : Recycled PVC. Net weight : 40kg.

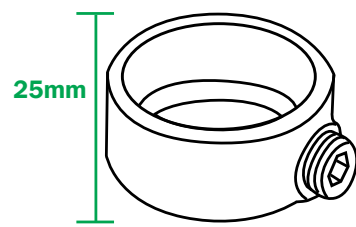
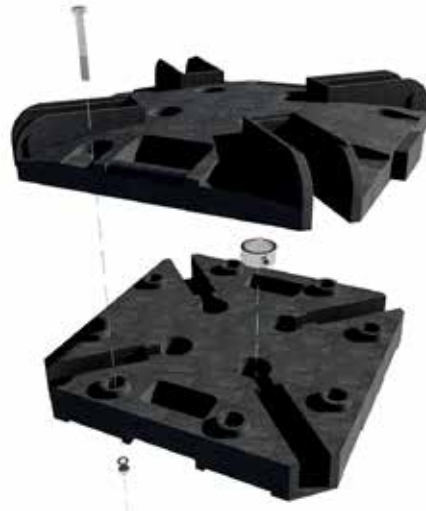

COLLAR - 75-8 *

These components are inserted into the bottom half of the recycled PVC Counter Weight. They are held in position via the inserts and on completion of assembling the top half of the Recycled PVC Base via the nuts and bolts provided. Once the Vertical Support Leg is inserted into the Recycled PVC Base Foot the collar is tightened to secure the Vertical Support Leg.
Material : Malleable cast iron to BS 1562 and galvanised to BS EN ISO 1461. Net weight : 0.19kg.

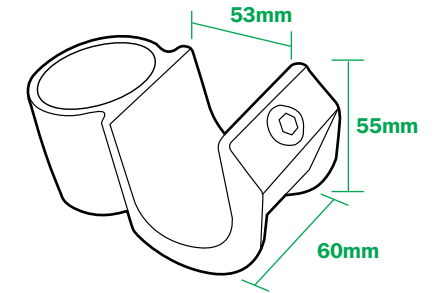

*SADDLE CLAMP - 135-8

This open cup fitting provides the method of linking the horizontal Main Rail Tubes to the Support Legs. Material : Malleable cast iron to BS 1562 and galvanised to BS EN ISO 1461. Net weight : 0.77kg.

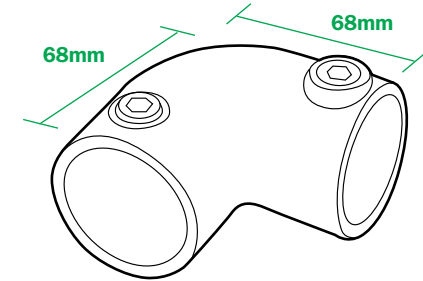

90° ELBOW - 15-8

This provides the means of dealing with corners and changes in level.
Material : Malleable cast iron to BS 1562 and galvanised to BS EN ISO 1461. Net weight : 0.76kg.

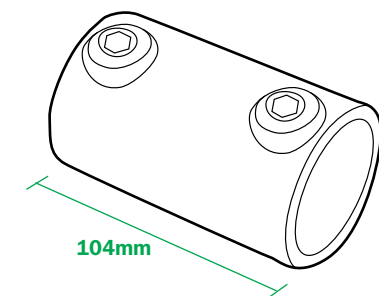

STRAIGHT COUPLING - 14-8

This component provides the method to link the horizontal Main Rail Tubes.
Material : Malleable cast iron to BS 1562 and galvanised to BS EN ISO 1461. Net weight : 0.6kg.

** Sold as replacement parts only*

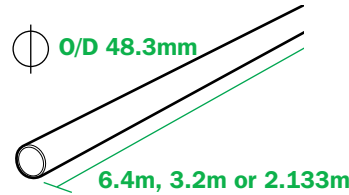

MAIN RAIL TUBE

EN 13374 (2.9mm wall thickness) **(6.4m - 8310)(3.2m - 8310HL)(2.133m - 8310213)**

Supplied in three sizes for convenience, these components provide the horizontal rails of the system. Guardrail top and intermediate rails are produced in steel - 48.3mm external diameter. Material : Steel tubing to BS EN 10255 - 2.9mm All steel components galvanised to BS EN ISO 1461. Net weight : 22.9kg, 11.45kg. & 7.6kg

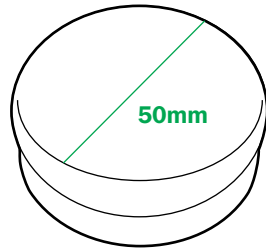

PLASTIC CAP - SL105

This component is fitted to the top of the Support Leg to prevent water ingress. Material : PVC. Net weight : 0.009kg.

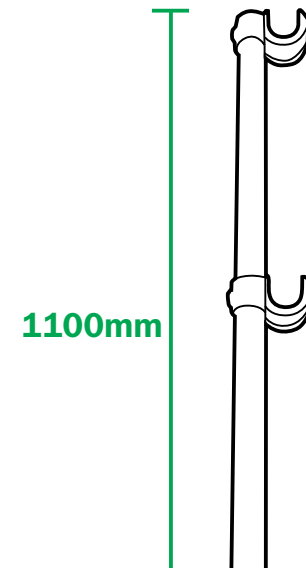

STANDARD SUPPORT LEG - KGUC

This component allows for standard 90° installation. The Vertical Support Legs are produced in steel - 48.3mm external diameter. (Wall thickness 3.2mm) Material : Steel tubing to BS EN 10255 - 2.9mm. All steel components galvanised to BS EN ISO 1461. Net weight : 5kg.

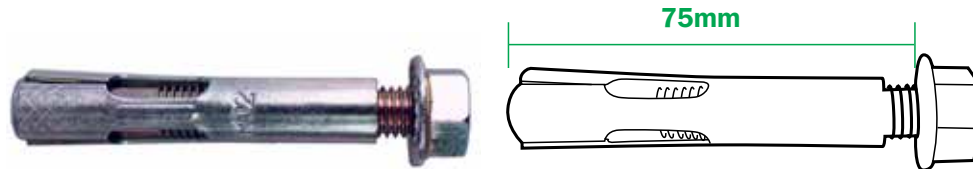

WALL FIXING - SL110

The wall fixing is used in pairs in conjunction with a Wall Clamp. Material : Stainless steel. Net weight : 0.064kg.

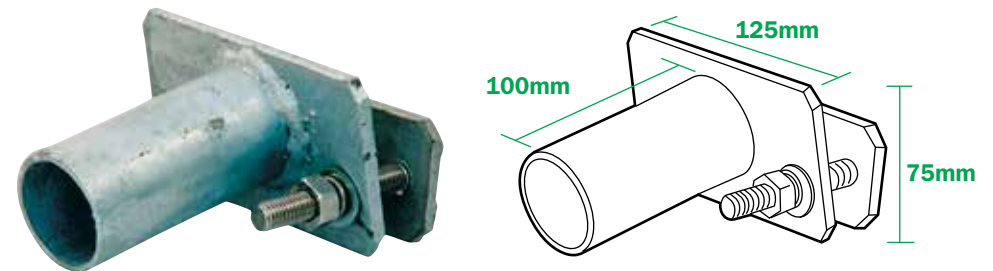

WALL/LADDER CLAMP - SL109C

This component provides the means to terminate the system against a façade or clamp the system to a cat ladder/structure where the stringer is a maximum of 70mm wide. Material : Galvanised steel to BS EN ISO 1461. Net weight : 1.1kg.

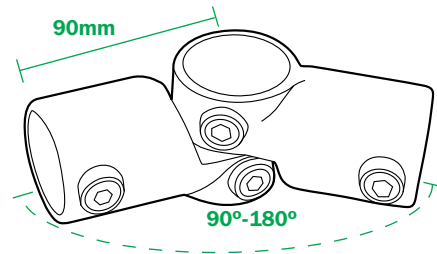

ADJUSTABLE SIDE OUTLET TEE ELBOW - 19-8

Used in pairs these components deal with angles 90°-180° and changes in level.
 Material : Malleable cast iron to BS 1562 and galvanised to BS EN ISO 1461.
 Net weight : 1kg.

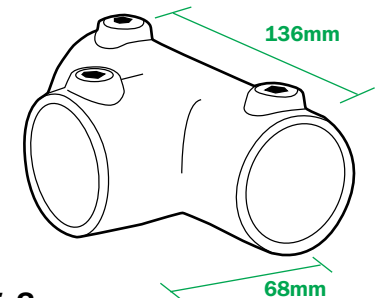

THREE SOCKET TEE CONNECTOR - 25-8

This component can be used in many different instances, for example, changes in level.
 Material : Malleable cast iron to BS 1562 and galvanised to BS EN ISO 1461.
 Net weight : 1.08kg.

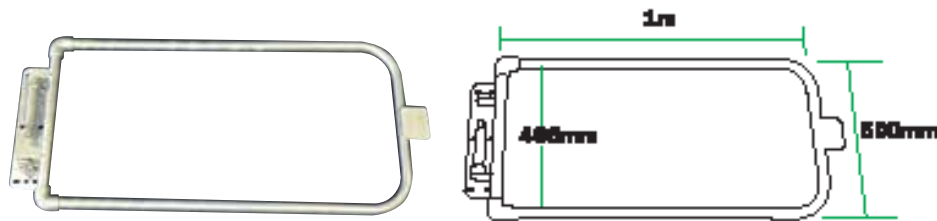

European Gate - Galvanised - SGEU500GV

Spring Loaded, self-closing safety gate. Manufactured from steel to EN 10255. 33.7mm diameter tube x 3.2mm wall thickness to meet requirements of EN 13374 & EN 14122. Complete with fixing pack.
 Material : Galvanised steel to BS EN ISO 1461. Net weight : 11kg (24lb 4oz).

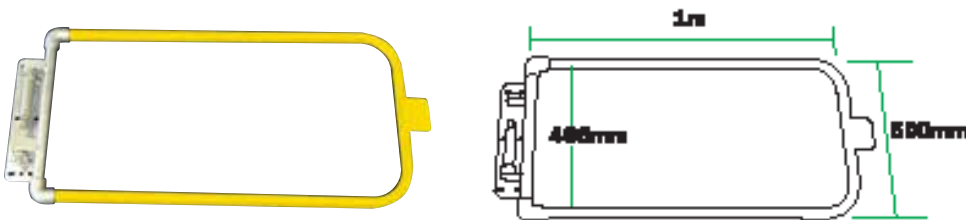

European Gate – Powder Coated - SGEU500PC

Spring Loaded, self-closing safety gate. Manufactured from steel to EN 10255 33.7mm diameter tube x 3.2mm wall thickness to meet requirements of EN 13374 & EN 14122. Complete with fixing pack. Powder Coated Finish to EN 13438.
 Material : Steel to EN 10255. Net weight : 11kg (24lb 4oz).



Alternative: KeeGuard counterweights can be used where returns cannot be used.

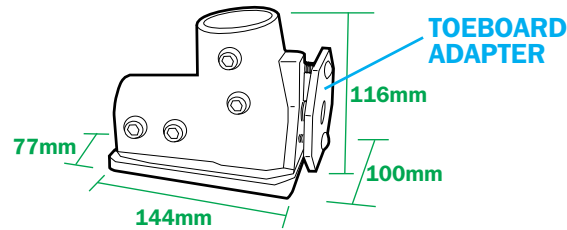

***BASE FOOT - 11308-7510 (T1308-7510-TOE-BOARD-OPTION)**

This unique component provides support to the system and allows the system to be set at 90° or raked back at 11°. The Base Foot connects the Cantilever Tubes and Counter Weights. The base is bonded with fluted rubber matting for membrane protection.

Material : Malleable cast iron to BS 1562 and galvanised to BS EN ISO 1461. Net weight : 1.9kg.

REPLACEMENT RUBBER PAD - K1351-4080

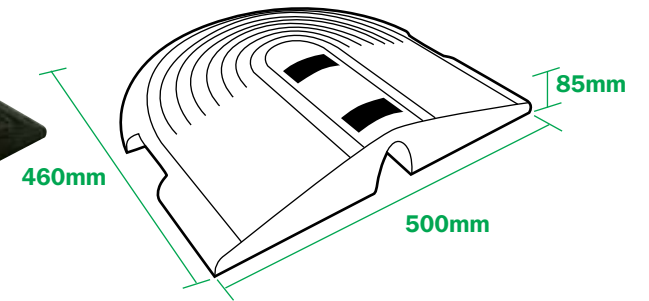

***RECYCLED PVC COUNTER WEIGHT - 440-7**

This component provides the stability to the system.

Material : Recycled PVC Net weight : 13.3kg.

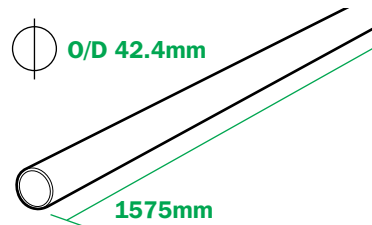

CANTILEVER TUBE - 1575mm - CBT2

Where a free standing end is required this component provides the link between the Counter Weight and Base Foot.

Material : Steel tubing to EN 10255 - 3.2mm. All steel components galvanised to BS EN ISO 1461. Cantilever tubes are produced in steel – 42.4mm external diameter. Net weight : 4.48kg

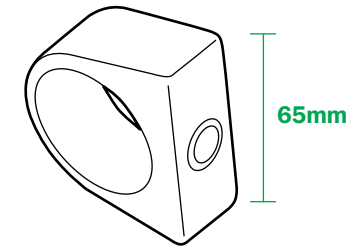

COLLAR - 74-7

This component is inserted in the first slot of the recycled PVC Counter Weight. The cantilever tube is pushed through this fitting and the grub screw is then tightened. This component provides the connection between the Cantilever Tube and the Counter Weight.

Material : Malleable cast iron to BS 1562 and galvanised to BS EN ISO 1461. Net weight : 0.24kg.

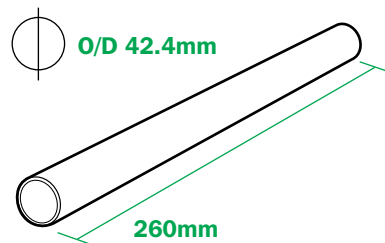
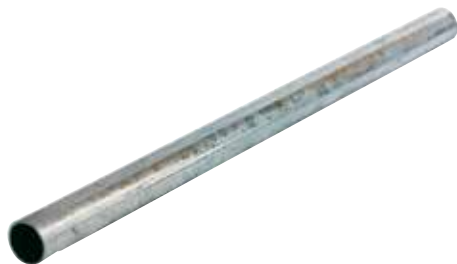

SMALL CANTILEVER TUBE/COUNTER WEIGHT LINK - CBT3

Used in pairs at the end details these components provide the link between the Counter Weights and the Cantilever Tube via the Two Socket Cross fitting. Material : Steel tubing to EN 10255 - 3.2mm. All steel components galvanised to BS EN ISO 1461. Tubes are produced in steel – 42.4mm external diameter. (Wall thickness 3.2mm) Net weight : 0.78kg.

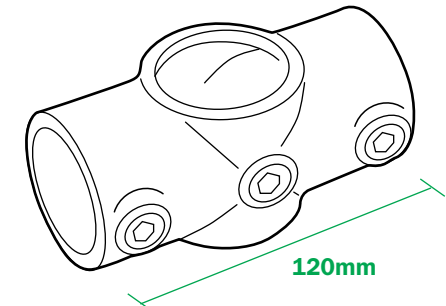

TWO SOCKET CROSS - 26-7

This component is used where two recycled PVC Counter Weights need to be joined together to form a counter weight end detail. Material : Malleable cast iron to BS 1562 and galvanised to BS EN ISO 1461. Net weight : 0.63kg.

Before starting, check you have all the individual parts. Select a suitable location for installation and remove any grease, oil or debris from the roof.

Standard chipping coverage depth is 15mm, should the chipping coverage exceed this, longer upright tubes will be required to maintain the 1100mm top rail height.

Tools Required

- Ratchet & Hex socket bit size 8mm AF
- 300mm Extension Bar to suit above
- Torque wrench 10-60 Nm approx



Premium Recycled PVC Base Foot (220-8)

Note: It is recommended that Spartan or Elastomer tiles are placed under all PVC Base Feet in order to distribute the weight of the system over a greater area to protect asphalt and mineral felt roofs from damage.

The guardrail must always end on a Weighted Leg, the only exception to this rule is if the guardrail can be fixed to a suitable structure i.e. brick/concrete walls.



WALL CLAMP

Extra components

- 1No. End piece
- 1No. Three Socket Tee Connector (25-8)
- 1No. Wall/Ladder clamp (SL109C)
- 2No. 90° Elbows (15-8)
- 2No. Wall fixings (SL110)

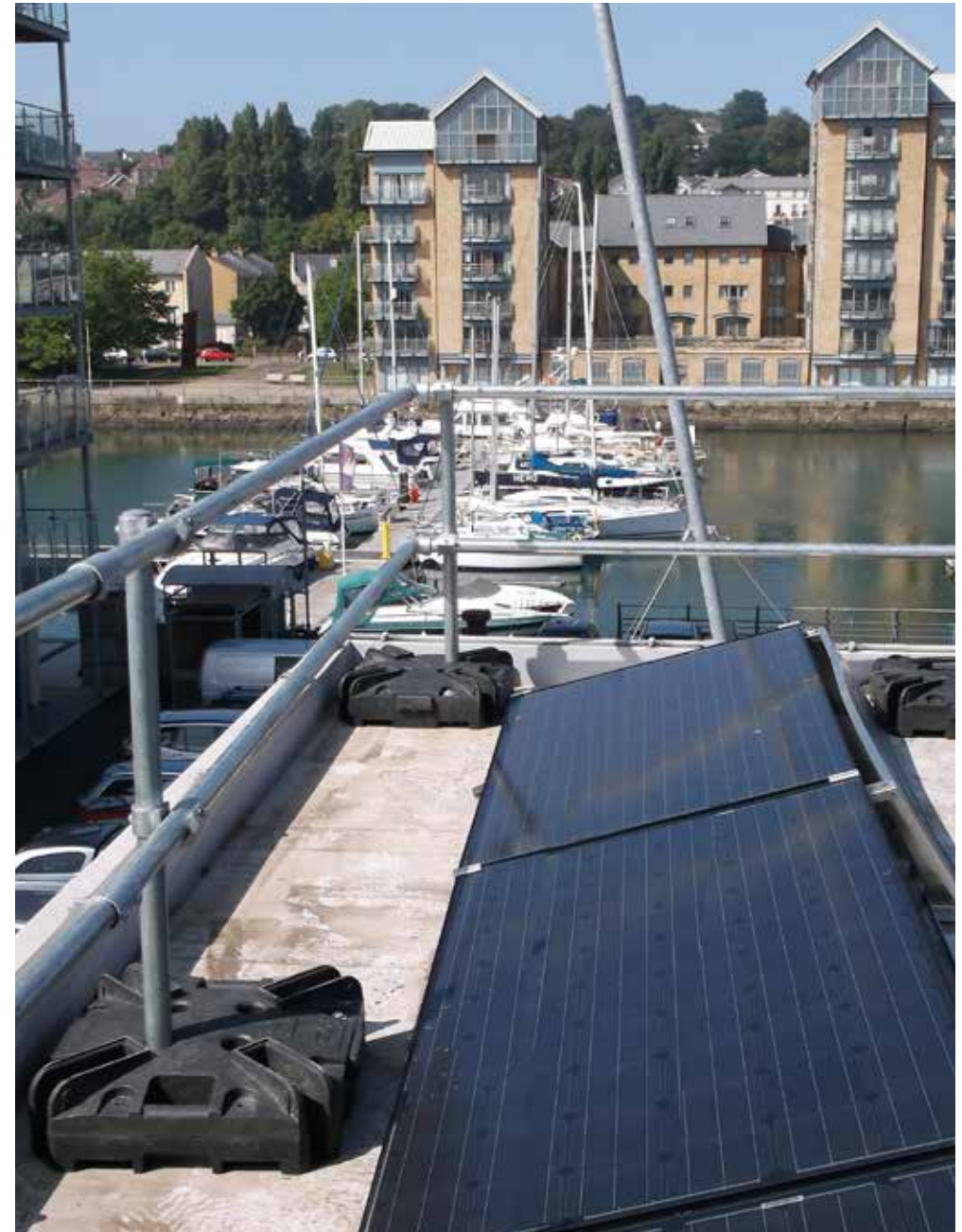

KeeGuard Premium Assembly Guide

STAGE 1

Lay out the equipment in approximately the positions shown in figure 1 below. Always ensure that you and the equipment are at a safe distance from the roof edge. The recommended distance is no less than 2 metres (See KeeGuard Premium/Contractor Layout illustrations).

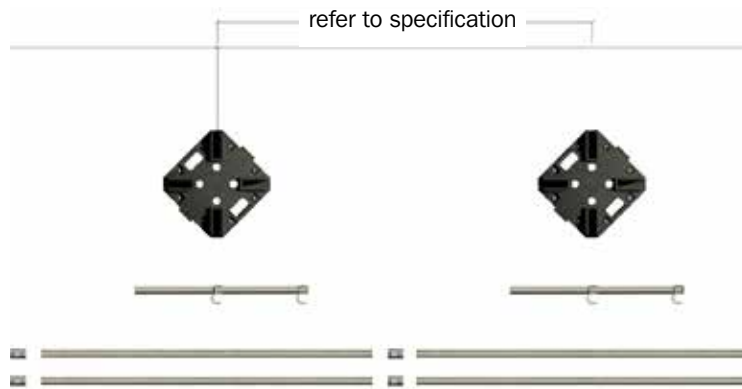

Figure 1.

STAGE 2

While tethered to the anchorage device, move the Premium PVC Base Feet to the exposed edge working from the centre of the run of guardrail towards the corner or Free Standing End (Refer to technical specification for the exact recommended centres.). Ensure point A faces the roof edge (figure 2).

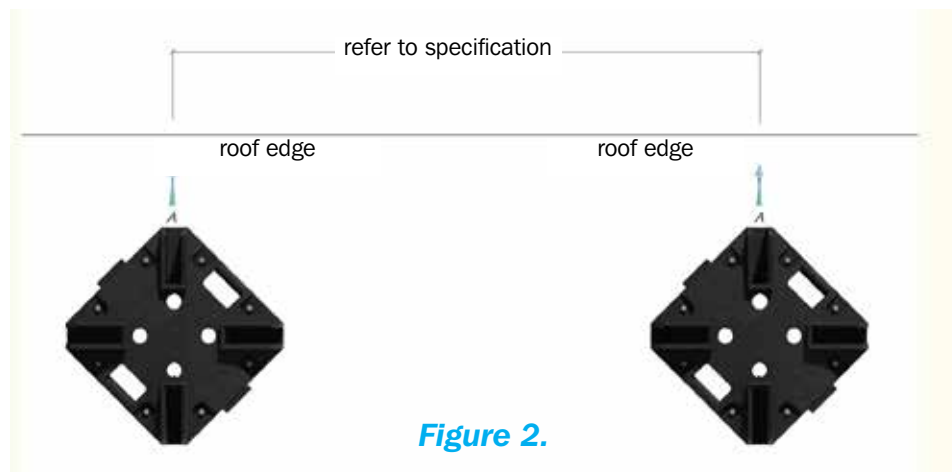

Figure 2.

STAGE 3

Fit each support leg (KGUC) into each PVC Base Foot, slotting the leg into the hole closest to the roof edge. Ensure the support legs are in line with each other and are fully located at the bottom of the hole. DO NOT tighten the Locking Collar (75-8) at this stage.

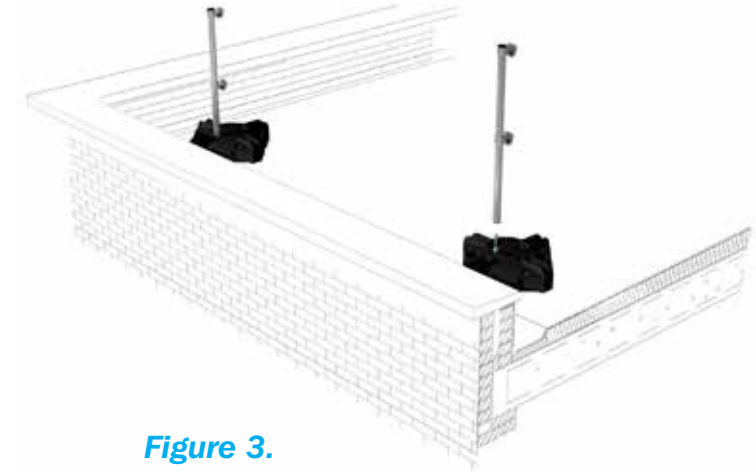

Figure 3.

STAGE 4

Place a Main Rail Tube (8610) into the bottom Saddle Clamp (135-8) of each of the legs. Position the tube so there is at least 60mm protruding from the Saddle Clamp and tighten the grub screw. These are located on the front of the Saddle Clamp. Place the second Main Rail Tube into the top Saddle Clamp, positioning the tube as before, leaving at least 60mm of the tube protruding from the Saddle Clamp and tighten the grub screw of the Saddle Clamp.

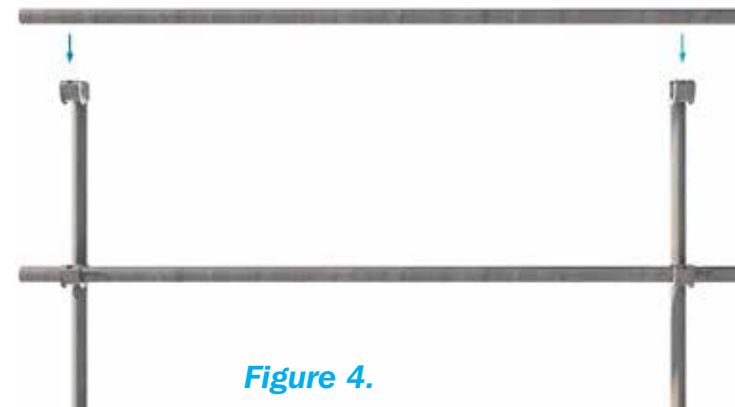

Figure 4.

STAGE 5

At each end of the rail loosely fit a Straight Coupling (14.8). Take another 3.2m tube and drop it into the next section of uprights and then slide back against the previously fitted rail with the Straight Coupling attached. Centralise the Straight Coupling over the rail joint and tighten the screws to a torque of 38Nm. Repeat for further sections. For added rigidity, ensure that the Straight Couplings are fitted with the grub screws facing outwards. (See figure 5)

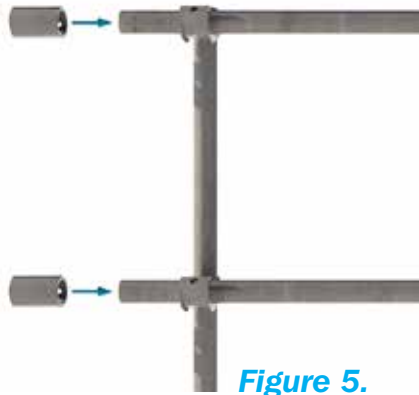

Figure 5.

At any corner connect to the next run of guardrail by using 2No 90° Elbows (15-8). Connect one of these to the top and one to the bottom of the Main Rail Tubes (8610). Slide a Main Rail Tube into the bottom Saddle Clamp (135-8) and 90° Elbow. Slide a Main Rail Tube into the top Saddle Clamp and 90° Elbow. Tighten the grub screws of all clamps. (See figure 6)

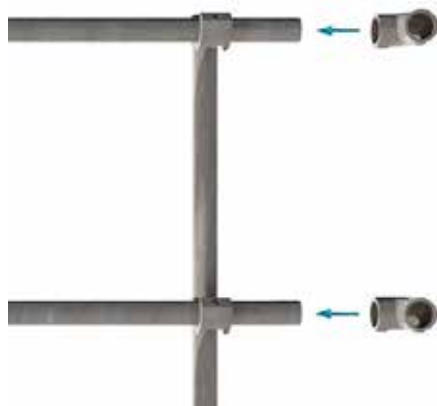

Figure 6.

STAGE 6

Free Standing End Detail

Slide 1No. Two Socket Cross (26-7) on to the free end of the Cantilever Tube (CBT2). Do not tighten at this stage. Slide two Small Cantilever Tubes (CTB3) into the free ends of the Two Socket Cross (26-7) and tighten the grub screws holding these tubes into position. Place a Collar (74-7) in the front slot of each of the 3No. PVC Counter Weights. Slide the PVC Counter Weights onto the free end of the Cantilever Tubes. Position all PVC Counter Weights as far from the Base Foot as practically possible. Line and level the guardrail. Tighten all grub screws.

Note: Refer to standard specification pages.



Figure 7.

6A RETURN DETAIL

Where possible a 1.5m (5') return can be used to terminate the system.

Form a corner via connect 1No 90° Elbows (15-8) to each of the top and bottom Main Rail Tubes (8610).

Place a PVC Base Foot (220-8) in the desired position and fit a support leg (KGUC) into the one of the holes. Ensure the support legs are in line with each other and are fully located at the bottom of the hole. **DO NOT** tighten the Locking Collar (75-8) at this stage.

Slide a Main Rail Tube into the top Saddle Clamp and 90° Elbow.

Slide a Main Rail Tube into the bottom Saddle Clamp and 90° Elbow

Tighten the grub screws of all clamps.

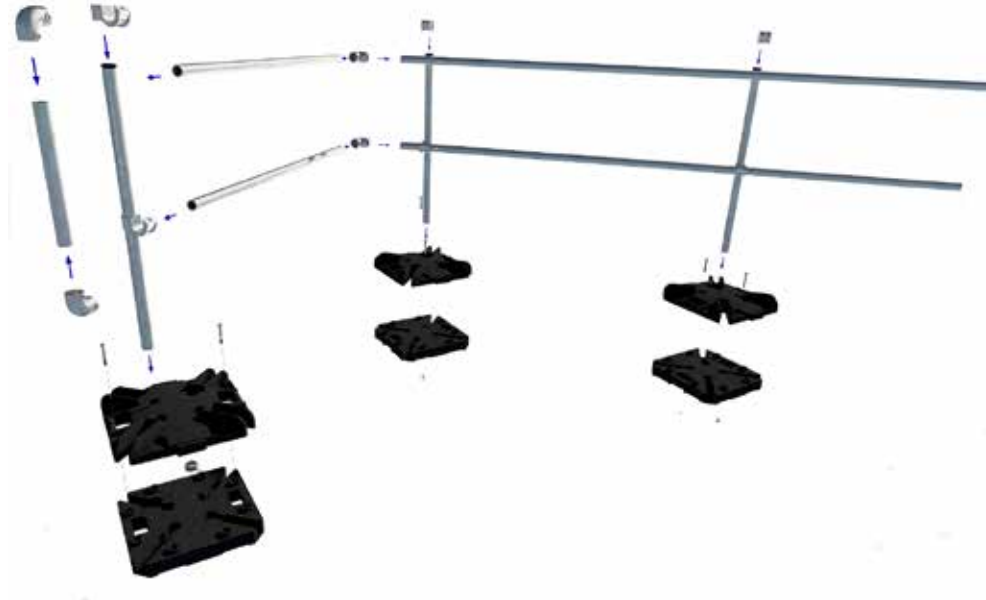

Figure 7a.

STAGE 7

Finally, tighten all the securing screws, including the Locking Collar within Premium Base, by applying a tightening torque

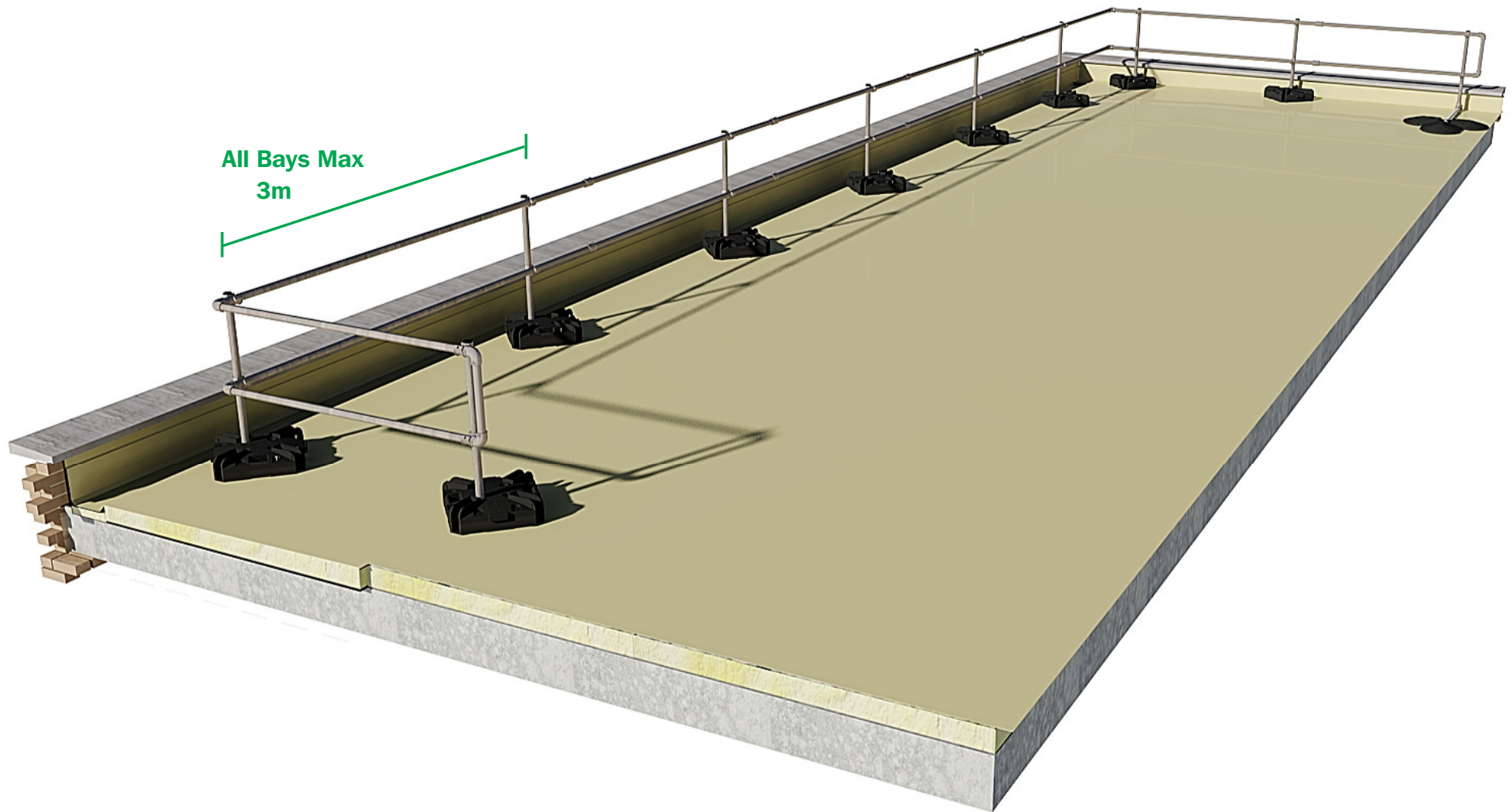

Figure 8.

WARNING

Under no circumstances should any person be anchored to the system for fall arrest purposes. Further, components such as timber infill, advertising boards, polyethylene sheets must not be fixed to the system.

For installation guidance on to pitch single ply membrane roofs with a parapet or up-stand, please contact KeeSafety.



Guardrail Systems Recertification

- Periodic inspections by a competent person are recommended by the manufacturer. In UK/Europe these are required under Regulation 5 of the Workplace (Health, Safety & Welfare) Regulations, the Work at Height Regulations and BS EN 365. The frequency will depend upon the environment, location and usage but should be at least every 12 months.
- Walk and visually inspect the complete installed system in relation to the general client's needs. Establish if any modifications and/or additional products are required to reflect any refurbishment requirements or additional plant & equipment which have been installed and require access.
- Check installation configuration is complete as per the original installation drawing/plan.
- Ensure the system has not been modified or tampered with by unauthorised persons.
- Check all base feet are in contact with the roof membrane.
- Check all counter weights are in place as per the original drawing. This is essential for wind loading calculations.
- Check all grub screws are in place, greased and sufficiently torque.
- Check that the general height and level of the system including the leg centres.
(This only tends to be an issue if the system has been tampered with between inspections).
- Any galvanised components showing signs of corrosion should be wire brushed thoroughly and galvanised spray/paint applied as appropriate.
If rusted significantly, take digital photographs and include these in the inspection report.
- Where toe-boards are fitted check the brackets that support the toe-board are in place, greased and sufficiently torqued.
- Where applicable, check fixings to walls/structures including cat ladder clamps are in place, greased and sufficiently torqued.
- Check system plaque position & mark up to reflect date of the next required inspection. Establish if additional plaques are required due to any refurbishment works.





Kee Safety Limited
Cradley Business Park
Overend Road, Cradley Heath
West Midlands B64 7DW

Phone: +44 (0) 1384 632 188
Fax: +44 (0) 1384 632 192
sales@keesafety.com
www.keesafety.co.uk